

The subterranean aquatic fauna of the North West Cape peninsula, Western Australia.

W.F. Humphreys* and M. Adams†

Abstract

The current status of the subterranean aquatic fauna on the semi-arid tropical North West Cape peninsula of Western Australia is discussed and placed in the context of the rich troglobitic fauna of Cape Range. The range of all four subterranean species has been considerably extended and an amphipod added to the known fauna. The fauna includes the only vertebrate troglobites known from Australia.

The Blind Cave Eel, *Ophisternon candidum*, has been seen for the first time in more than a decade and from the east coast of the peninsula where it was previously unknown. Allozyme electrophoretic data show that the Blind Gudgeon, *Milyeringa veritas*, is not panmictic within its known range. The overt geological discontinuities along the coast of the North West Cape peninsula do not constitute genetic barriers between the gudgeon populations.

Allozyme electrophoretic data confirm that two species of atyid shrimps occur but the species were found on opposite sides of the peninsula. Analysis suggests that the species composition on the east coast is different from that on the west coast.

The relationship between genetic and metric distance between the populations suggests that the coastal fauna is essentially linear along the coast and does not spread beneath Cape Range.

Within Cape Range all four wells with water contain an undescribed amphipod. Allozyme electrophoretic data suggest the presence of a single species showing genetic discontinuities through its range.

There is a cline in the water chemistry, with most parameters increasing from the mid-east coast, round the north coast and south along the west coast of the peninsula. All coastal species seem to occupy the full range of water chemistries sampled. There is a lack of effective monitoring of the quantity and quality of the water. Examination of diverse evidence from a number of sources suggests that the water table is declining and becoming more saline. Potential disruption of the habitat is discussed and a model presented which indicates that the critical areas for conservation may be close to the scarp where, owing to the absence of wells, the fauna has not been sampled.

Introduction

The troglobitic fauna of the North West Cape peninsula of Western Australia was first mentioned in the context of the subterranean freshwater fauna of the coastal plain (Whitley 1945) and later by Cawthorn (1953). This fauna was the focus of a paper by Mees (1962) who described the composition and known range of the fauna. Since then the known range of the fauna has expanded considerably but the species composition has remained unchanged. In addition, a rich troglobite fauna has been found within

*Department of Invertebrate Biogeography and Ecology, Western Australian Museum, Francis Street, Western Australia 6000

†Evolutionary Biology Unit, South Australian Museum, North Terrace, Adelaide, South Australia 5000

Cape Range, which forms the spine of the peninsula (Vine, Knott & Humphreys 1988; Humphreys 1989, 1990; Humphreys, Adams & Vine 1989).

Nearly three decades after Mees's (1962) publication it is pertinent to review what is known of the four troglobitic species of the coastal plain and relate it to the troglobitic fauna of the peninsula as a whole (Figure 1). Since that time the peninsula has started to be developed rapidly as an international tourist region and two major national parks have been established (Cape Range National Park and the contiguous Ningaloo Marine Park). This trend represents both quantitative and qualitative changes to the human impact on the region. For this unique troglobite fauna to survive the development must be sensitive to its needs.

More than 300 caves and wells are known from Cape Range, many containing a rich troglobitic fauna of terrestrial arthropods, while an undescribed amphipod inhabits the four caves containing water (Vine, Knott & Humphreys 1988; Humphreys 1989, 1990; Humphreys, Adams & Vine 1989). This fauna is distinct from that inhabiting the subterranean waters on the ca. 2 km wide coastal plain fringing Cape Range which contains a unique subterranean fauna, comprising two species of fish and two species of atyid shrimps. Although these taxa were described between 1945 and 1962, almost nothing is known of their biology. Some coastal caves, which were major water sources for aboriginal people (Carter 1902), and recent bores, have been heavily utilized for water by pastoralists, Exmouth Town and military facilities.

This paper reviews the status of the subterranean aquatic fauna of the North West Cape peninsula and shows the lack of information on the biology and dynamics of species involved.

The fauna

Four species are known to occur in the subterranean freshwater on the coastal plain. The Blind or Cave Gudgeon, *Milyeringa veritas* Whitley 1945 (Perciformes: Eleotridae) (Whitley 1960) was described from Milyering Well (cave number C-24). It is classified as rare and total protection has been recommended (Michaelis 1985). The Blind Cave Eel, *Ophisternon candidum* (Mees 1962) (Synbranchiformes: Synbranchidae) was described from Tantabiddi Well (C-26). It is classified as vulnerable (Michaelis 1985). These two species of fish comprise the entire troglobitic vertebrate fauna of Australia. The atyid shrimps *Stygiocaris lancifera* Holthuis 1960 and of *S. stylifera* Holthuis 1960 (Decapoda: Natantia) were both described from Kudumurra Well (C-25). The Indo-West Pacific area seems to be deficient in troglobitic Decapoda compared with e.g. the Mediterranean and the West Indies (Holthuis 1960). The four species known from the coastal limestone are endemic to the peninsula and co-occur in the same water bodies (Mees 1962, Hamilton-Smith 1967).

Within Cape Range itself amphipods occur in each of the four caves known to contain standing water viz. C-18, C-64, C-103 and C-163 (Humphreys 1989, 1990; Humphreys, Adams & Vine 1989). The amphipoda are of marine origin and part of the *Victoriapisa* complex (Gammaridae; B. Knott; pers. comm. 1988).

Methods

Numbers with a C- prefix refer to caves or karst features described in the karst Index of Cape Range (M. East and B. Vine; pers. comm.). They will eventually be included in the Australian Speleological Federation's catalogue of karst features.

Table 1. Location and distribution of samples collected for genetic analysis in 1989. The gudgeons are *Milyeringa veritas*, while the shrimps are *Stygiocaris lancifera* except for those from Mowbowra Well and Kubura Well which are *S. stylifera*.

Cave	Name	Location	Shrimps	Numbers	
				Gudgeons	Amphipods
C-18	Dry Swallett	22°05'S; 114°00'E	—	—	4
C-24	Milyering Well	22°01'S; 113°56'E	4	—	—
C-25	Kudamurra Well	21°53'S; 114°01'E	4	5	—
C-27	Kubura Well	21°56'S; 114°08'E	8	3	—
C-64	Shot Hole Tunnel	22°03'S; 114°01'E	—	—	9
C-103	Trionomo	22°07'S; 113°59'E	—	—	4
C-149	Tulki Well	22°06'S; 113°54'E	4	5	—
C-163	Wanderer's Delight	22°09'S; 114°00'E	—	—	9
C-273	5 Mile Well	21°51'S; 114°04'E	4	7	—
C-274	Pilgramunna Well	22°12'S; 113°52'E	—	5	—
C-361	Mowbowra Well	22°00'S; 114°07'E	3	3	—
C-362	Javis Well	22°36'S; 113°41'E	—	2	—

Distribution

Distributions of the taxa have been ascertained incidentally from a series of expeditions examining the troglobitic fauna of Cape Range, by records in the literature and from discussion with people who have examined the caves over a long period. Collections of shrimps and fish were made in September 1989 as detailed in Table 1.

A total of 24 sites, including all known locations for the subterranean coastal fauna were visited with the aim of collecting a minimum of six specimens each of shrimps and gudgeons to be divided between alcohol-preserved material and liquid nitrogen material for genetic analysis. The small number of specimens and few sites of collection (Table 1) attest to the sparsity of the fauna. The following sites were visited: 4-mile Well, 5-mile Well (C-273), Bundera Rockhole (C-28), C-215, Cape Well, Dozer Cave (C-23), Javis Well (C-362), Kuburu Well (C-27), Kudumurra Cave, Kudumurra Well (C-25), Milyering Cave (C-172), Milyering Well (C-24), Mowbowra Well (C-361), Nabalgee Well, Ned's Well, Pilgramunna Well (C-274), South Yardie Well (C-275), Tantabiddy Well, Trealla Well, Tulki Well (C-149), unnamed small rockhole near south ranger's camp, unnamed small rockhole south of Bundera Rockhole, unnamed well (old water supply for NorWest Seafoods) and Woolcott Well.

Water analysis was conducted using standard methods (American Public Health Association 1965) except for pH which was determined at the time of collection using narrow range pH papers (Merck).

Electrophoresis

Cellulose acetate gel electrophoresis was conducted using standard methods (Richardson, Baverstock & Adams 1986). Homogenates were made from whole individuals of four taxa (*Milyeringa veritas*, *Stygiocaris lancifera*, *S. stylifera* and the amphipods) and used to examine the allozyme variation between the populations around the peninsula. Samples were available from between four and seven natural or artificial wells or caves depending on the taxon under study. For systematic purposes, the null hypothesis under test was that all populations were sampled from the gene pool of a single species. A large number of enzymes and non-enzymic proteins were examined (Table 4), of which 37 displayed electrophoretic patterns suitable for reliable genetic interpretation in at least one of the four taxa. The enzymes used are as follows: aconitate hydratase (ACON, E.C. 4.2.1.3), aminoacylase (ACYC, E.C. 3.5.1.14), adenosine deaminase (ADA, E.C. 3.5.4.4), alcohol dehydrogenase (ADH, E.C. 1.1.1.1), adenylate kinase (AK, E.C. 2.7.4.3), aldolase (ALD, E.C. 4.1.2.13), alkaline phosphatase (AP, E.C. 3.1.3.1), arginine kinase (ARGK, E.C. 2.7.3.3), carbonate dehydratase (CA, E.C. 4.2.1.1), creatine kinase (CK, E.C. 2.7.3.2), diaphorase (DIA, E.C. 1.6.99.?), enolase (ENOL, E.C. 4.2.1.11), esterase (EST, E.C. 3.1.1.1), fructose-1, 6-diphosphatase (FDP, E.C. 3.1.3.11), fumarate hydratase (FUM, E.C. 4.2.1.2), glyceraldehyde-phosphate dehydrogenase (GAPD, E.C. 1.2.1.12), guanine deaminase (GDA, E.C. 3.5.4.3), lactoyl-glutathione lyase (GLO, E.C. 4.4.1.5), aspartate aminotransferase (GOT, E.C. 2.6.1.1),

Table 2. The current status of the subterranean fauna on the North West Cape peninsula. Mees refers to Mees (1962). ✓=reported to occur. —= not found and never reported.

Cave #	Name	Shrimp	Gudgeon	Eel	Salinity (‰)		pH 1988
					1983	1988	
—	Unnamed	✓	—	—	—	—	—
—	Woolcott Well	—	—	—	—	—	7.0
—	Nabalgee Well	—	—	—	—	—	7.3
—	4-Mile Well	none	none	—	—	—	7.6
C-23	Dozer Cave	none	few	—	—	—	—
C-24	Milyering Well	Mees ¹	1989	Mees	5	4	7.4
C-25	Kudamurra Well	1989	Mees ¹	Mees	—	2	7.3
C-26	Tantabiddy	none	none	Mees	—	3	—
C-27	Kubura Well	1989	1989	1973	—	—	6.8
C-28	Bundera Sinkhole	—	1988	—	—	16	—
C-105	The Gnamma Hole	none	none	1988	1	—	—
C-149	Tulki Well	1989	1989	—	5	5	7.5
C-215	Unnamed	none	1989	—	—	—	7.3
C-273	5 Mile Well	1989	1989	—	—	—	—
C-274	Pilgramunna Well	1989	1989	—	—	—	7.5
C-332	—	1977	—	—	—	—	—
C-361	Mowbowra Well	1989	1989	1989	—	—	7.3
C-362	Javis Well	1989	1989	—	—	—	7.3

¹Also collected in 1989.

general protein (GP), glucose-phosphate isomerase (GPI, E.C. 5.3.1.9), alanine aminotransferase (GPT, E.C. 2.6.1.2), glutathione reductase (GSR, E.C. 1.6.4.2), hexosaminidase (HEX, E.C. 3.2.1.30), hexokinase (HK, E.C. 2.7.1.1), isocitrate dehydrogenase (IDH, E.C. 1.1.1.42), leucine amino peptidase (LAP, E.C. 3.4.11.1), lactate dehydrogenase (LDH, E.C. 1.1.1.27), malate dehydrogenase (MDH, E.C. 1.1.1.37), malic enzyme (ME, E.C. 1.1.1.40), mannose-phosphate isomerase (MPI, E.C.5.3.1.8), peptidases (PEP, E.C. 3.4.11.? or 3.4.13.?), phosphoglycerate mutase (PGAM, E.C. 5.4.2.1), 6-phosphogluconate dehydrogenase (6PGD, E.C. 1.1.1.44), phosphoglycerate kinase (PGK, E.C. 2.7.2.3), phosphoglucomutase (PGM, E.C. 5.4.2.2), pyruvate kinase (PK, E.C. 2.7.1.40), L-idoitol dehydrogenase (SORDH, E.C. 1.1.1.14) and triose-phosphate isomerase (TPI, E.C. 5.3.1.1). The nomenclature and conventions for referring to alleles and loci follow Richardson, Baverstock & Adams (1986).

All species met the criteria for adequate genetic work at the within-species level (Richardson, Baverstock & Adams 1986) in that they had at least six polymorphic loci; the samples could be drawn from the smallest and homogeneous population units (wells or caves) and they were sampled over some geographical distance including the extremities and intermediate locations.

Results and Discussion

Distribution of the fauna

The distribution of the subterranean aquatic fauna of the North West Cape peninsula is outlined in Figure 1 and Table 2, together with salinity and pH readings from 1983 and 1988. The distributional range of each species has been considerably extended by this study over that detailed by Mees (1962). There are clearly inadequate data on the time course of the water chemistry as will be discussed more fully below.

The gudgeon, *Milyeringa veritas*, was known in 1962 from only two locations on the north-west coast of the peninsula, namely Milyering Well (C-24) and Kudamurra Well (C-25). It is now fairly widely known from south of Yardie Creek at Jarvis Well (C-362), round North West Cape and down the east coast as far as Mowbowra Well (C-361: Figure 1). The latter locality is south of the proposed Exmouth marina. The range extension since 1962 is ca 740%. The gut contents of four specimens contained detrital matter and the remains of diptera; it is not known whether the latter are taken live.

The eel, *O. candidum*, was known also in Mees's time (1962) only from Milyering and Kudamurra Wells on the north-west coast of the peninsula. In 1973 it was seen in Kubura Well (C-27) on the north east coast in Exmouth town site (Figure 1). The only known sightings in more than a decade have been south of the proposed Exmouth marina: in the Gnamma Hole (C-105: 29 May 1988 - M. East; pers. comm.) and in Mowbowra Well (C-361: 10 September 1989 - B. Vine; pers. comm.). In 1977 one was seen for several days in a recently excavated 4 m deep well south of Yardie Creek (Allen 1982). The range extension since 1962 is ca. 340%.

The shrimps, *Stygiocaris lancifera* and *S. stylifera* are here treated together as field observers have not been able to distinguish the two species; this point will be discussed

further below. Holthuis (1960) described the species sympatrically from both Milyering and Kudamurra Wells and unspecified water holes near Milyering. They are now known to occur from Tulki Well on the west coast, round North West Cape and down the east coast as far as Mowbowra Well (Figure 1). The latter locality is south of the proposed Exmouth marina. The range extension since 1962 is *ca.* 530% for *Stygiocaris lancifera* and 340% for *S. stylifera*. All range extensions were calculated assuming the fauna occupies only the coastal plain (see below).

The Cape Range amphipods (*Victoriapisa* complex) were not known in Mees' time and occur in a band about 12 km long in the central part of the range (Figure 1). Alcohol preserved material from each cave is held at the Western Australian Museum; Cape Range 1989 -3212, -3225, -3236, -3241; and WAM 954/88 to 98/8).

There are reports of 'shrimps' pumped from a bore further south on the east coast (M. East; pers. comm.), the west coast and from the bore field supplying Exmouth, but no specimens are known. Their identity cannot be assumed because the Exmouth bore field enters Tulki Limestone from which only the Cape Range amphipods have been confirmed.

Only 1.1 km from Milyering Well is a cave (C-215) within the same Tulki Limestone formation that contains the typical Cape Range troglobitic fauna (Humphreys 1989 and unpublished). The coastal water table is reached at a depth of 23.8 m (*ca.* +1.2 m MSL; cf +0.42 to +0.98 m MSL in Exmouth bores 1 to 6; Bestow 1966). This is the only locality known from the North West Cape peninsula where elements of both the Cape Range and the coastal fauna co-occur, namely the gudgeon and a troglobitic millipede (an undescribed genus of the Paradoxosomatidae [Craspedosomida]; W. A. Shear, pers. comm. 1989). Clearly the potential exists for the subterranean fauna to extend from close to the coast into the foothills of Cape Range proper (see below).

Numbers

No estimates of the continuity or abundance of this subterranean fauna has been made and so assessment of its status relative to the time of its discovery is impossible; detailed biological work is required to set this base line. The impression of those who have examined the wells over many years is that numbers are considerably lower than they once were. We present below the little information about numbers that can be deduced.

Mees (1962: 29) describes removing the *ca.* six visible specimens of the gudgeon from Milyering Well several times during one day as they were replaced by individuals from the subterranean channels. Several days later only one or two individuals were found on subsequent visits. The next year about six were seen again.

The collections made from which Holthuis (1960) described the shrimps are well documented as to the number of specimens; Snell's samples were collected mainly in May 1959 (a few in April 1957), and Mees and Douglas' samples were collected in August that year (Table 3). The proportion of the two species of shrimps, *Stygiocaris lancifera* and *S. stylifera*, did not differ between collectors (Table 3: $\chi^2_1 = 2.635$, $P=0.105$) or the two major collections (Table 3: $\chi^2_1 = 3.166$, $P=0.075$). Note the large number of

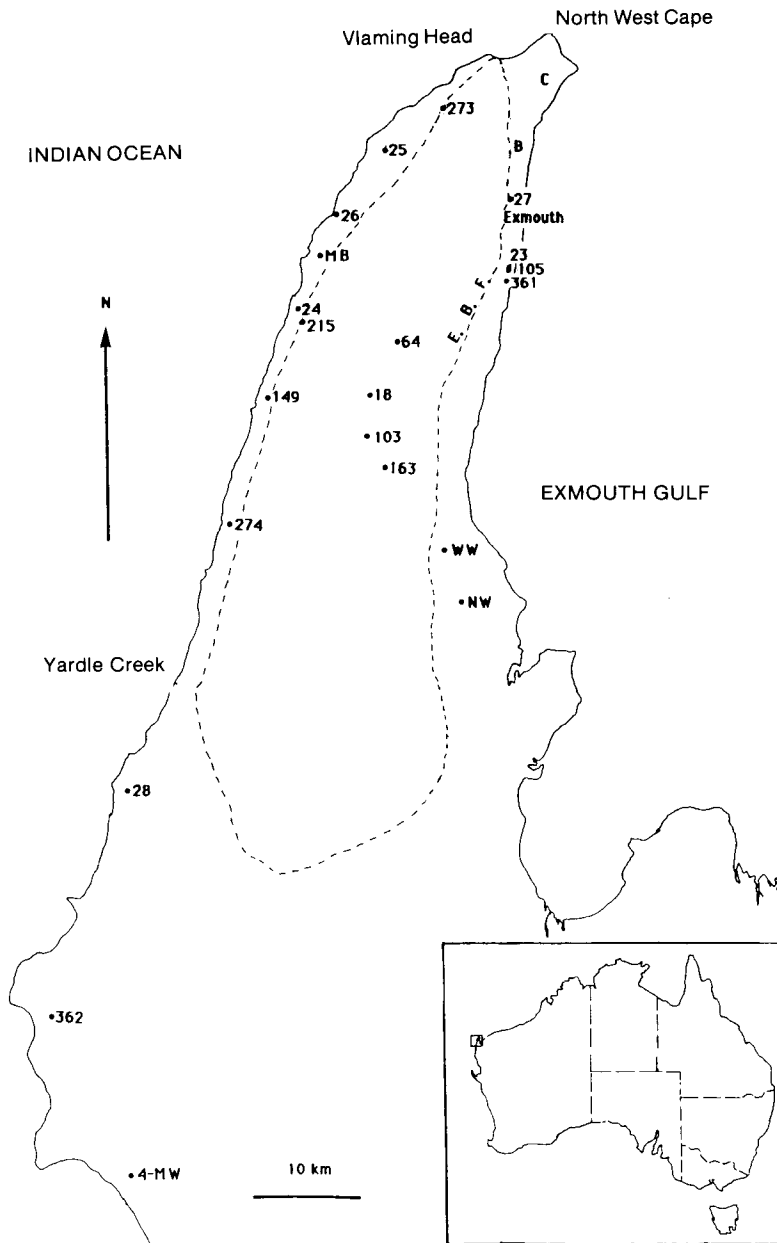

Figure 1. Map showing the North West Cape peninsula of Western Australia and the localities of wells, caves and other geographical features mentioned in the text. E. B. F. denotes the Exmouth bore field from which the town draws its water supply. The military facilities (B and C) have a separate water supply drawn from area B. The stippled line denotes the position of Cape Range. NW, Nabalgee Well; WW, Woolcott Well; 4-MW, 4-Mile Well. C-172 is adjacent to C-24. C-275 is 1 km ESE of C-28.

specimens collected in the wells at that time where it is now difficult to find several specimens.

In the samples collected for genetic analysis (below) all specimens from the west coast were of one genetic species while all those from the east coast were of another genetic species. Some specimens collected at the same time as the samples used for genetic analysis were fixed in formalin and preserved in alcohol. Comparison of these specimens with paratypes held at the Western Australian Museum shows all specimens from the west coast to be *Stygiocaris lancifera* Holthuis, while all those from the east coast were *S. stylifera* Holthuis (Table 3). The proportion of the two species of shrimps collected on

Table 3. The numbers of shrimps (*Stygiocaris* spp.) collected by various people and their locations. Data for Mees & Douglas and Snell are from Holthuis (1960).

Well	Collector	<i>S. lancifera</i>	<i>S. stylifera</i>
Kuddamurra	Snell	75	12
Kuddamurra	Mees & Douglas	56	2
Milyering	Snell	7	0
near Milyering	Snell	9	1
		147	15
West coast	Humphreys	20	0
East coast	Humphreys	0	24
		20	24
		167	39

the west coast in the 1950's (Mees 1962) and in 1989 did not differ (Table 3: $\chi^2_1 = 0.980$, $P = 0.322$), despite the total absence of *S. stylifera* in 1989. Hence, it is unclear whether there has been a change in the composition of the shrimp populations on the west coast as we may be considering a sampling artifact. However, there is a significant difference in the proportion of the two species collected on the east coast in 1989 and the earlier samples (Table 3: $\chi^2_1 = 106.05$, $P < 0.001$); hence, it seems that a real difference may exist between the shrimp communities on the east and west coasts.

Genetics of the subterranean fauna.

On the coastal plain of the North West Cape peninsula, within the known range of the subterranean aquatic fauna, there are two geological discontinuities which potentially could isolate water bodies. The first is at Vlaming Head (Figure 1), where a band of Vlaming Sandstone and the Pilgramunna Formation abut the coast. The second is the bisection of the coastal plain by Yardie Creek which exposes to the coast the Tulki Limestone in which the caves of Cape Range are formed (see surface geology maps in Condon, Johnstone & Perry 1955). The genetic analyses were conducted to test the null

hypothesis that species are panmictic throughout their range, and secondly, that the potential geological barriers do not constitute a barrier to gene flow around the coastline. A summary of the genetic analyses is given in Table 4 and the data are in Appendices 1-4.

Table 4. Summary of the genetic information.

Attribute	<i>Milyeringa veritas</i>	<i>Stygiocaris lancifera</i>	<i>Stygiocaris styliifera</i>	Amphipoda
*caves/ wells sampled	7	4	2	4
*individuals	24	16	11	25
*loci scored	43	28	28	28
*loci invariable (%)	12 (28)	21 (75)	22 (79)	13 (46)
*polymorphic loci (%)	31 (72)	7 (25)	7 (21)	15 (54)
More than one species? ¹	No	No	No	No
Panmictic population? ²	No	—	Yes	No
Geographic explanation	Yes	No	No	Yes
Troglobite	Yes	Yes	Yes	Yes

¹ Null hypothesis of all populations from the gene pool of a single species.

² Null hypothesis of panmixia not refuted using genetic data.

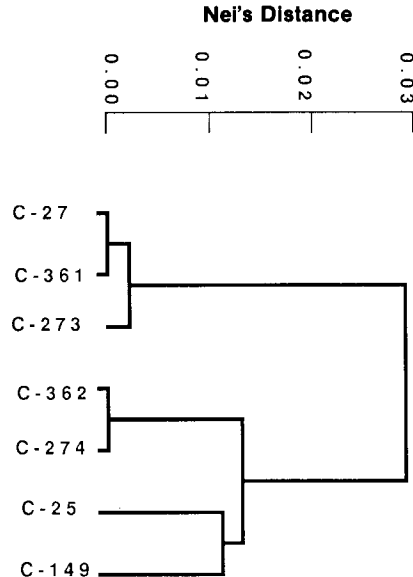

Figure 2. Dendrogram of the relationships between the populations of the The Blind Gudgeon, *Milyeringa veritas* from six localities on the North West Cape peninsula, based on Nei's Distance (corrected: see Appendix 1).

Gudgeon

Forty-three loci were scored of which 12 were found to be polymorphic. Examination of the genetic distances (Figure 2 and Appendix 1) shows that there are four populations separated by a Nei's Distance of >0.01 : the north and east coast, on either side of Yardie Creek, and two partly isolated populations on the mid-west coast. The populations on either side (C-362 and C-274) of Yardie Creek, 35 km apart, are very similar genetically (Figure 2, Appendix 1). Similarly, the geological discontinuity at Vlaming Head straddles populations 10 km apart (C-27 and C-273) which are also of close genetic similarity. Clearly, the two geological discontinuities do not constitute genetic barriers to the gudgeons.

Nevertheless, the gudgeon populations are not sampled from one panmictic gene pool. This was tested by pooling the data within the four groups identified in Figure 2. Four loci show significant departure from the distribution of allele frequencies expected in sample sets taken from a panmictic population, namely Gpi-1 ($\chi^2_1 = 8.89$, $P = 0.012$), Enol-2 ($\chi^2_1 = 17.55$, $P < 0.001$), Mdh-3 ($\chi^2_1 = 15.86$, $P < 0.001$) and Idh-2 ($\chi^2_1 = 17.12$, $P = 0.002$).

Shrimps

Twenty-eight loci were scored of which 9 were found to be invariant (Appendix 2). The electrophoretic data clearly demonstrate the presence of two species as the two genetic groups identified have 50% fixed differences, differing at 14/28 loci (Appendix 2), and they conform with the taxonomy of Holthuis (1960).

Examination of the genetic distances (Figure 3 and Appendix 2) shows two groups in the data for the west coast (*S. lancifera*), one from the extreme north-west of the peninsula and the other from the mid-west coast. The distribution of the species and the lack of common species between the east and the west coasts prevent testing the geological discontinuity hypothesis using the shrimp genetical data.

However, the data suggest that the populations on the west coast (*S. lancifera*) are not panmictic. This was tested by pooling the data within the two groups identified in Figure 3. The locus Got-1 showed significant departure from the distribution expected in a panmictic population ($\chi^2_1 = 18.31$, $P < 0.001$), while the locus Got-2 was significant if Yates correction is not applied ($\chi^2_1 = 4.57$, $P = 0.033$, or $\chi^2_1 = 2.93$, $P = 0.087$ with Yates correction), a matter of statistical debate. No significant departure from panmixia was detected for *S. stylifera* on the east coast.

Given the small size of the shrimps compared with the gudgeons, the genetic continuity of the latter between the east and west coasts suggests that there are no obvious barriers to the continuity of distribution in the shrimps. The data presented here do not demonstrate this. It is clear that suitable habitat for the gudgeons does not imply that the area is also suitable for the shrimps. In C-215, where the Cape Range troglobites and the coastal subterranean fauna co-occur, the gudgeons were common but shrimps were absent, despite once being present in Milyering Well, only 1.1 km away.

Amphipods

Twenty-eight loci were scored of which 13 were found to be invariant (Appendix 3). In

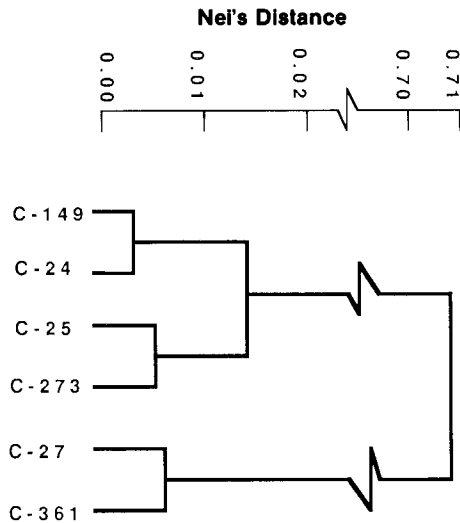

Figure 3. Dendrogram of the relationships between the populations of the atydid shrimps *Stygiocaris* spp. from six localities on the North West Cape peninsula, based on Nei's Distance (corrected: see Appendix 2). The four localities on the left represent *Stygiocaris lancifera*, while the two to the right represent *S. stylifera*. Note the break in the scale.

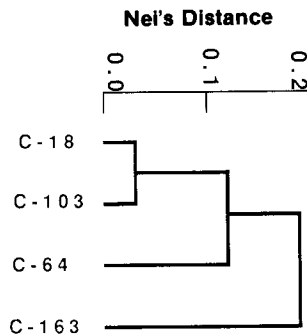

Figure 4. Dendrogram of the relationships between the populations of the amphipods from the four caves in Cape Range known to contain standing water. It is based on Nei's Distance (corrected: see Appendix 3).

contrast to the other taxa, there is evidence of considerable genetic divergence between the four cave populations (Appendix 3, Figure 4). Populations C-18 and C-103, in the centre of the distribution, are genetically similar, displaying minor differences in allele frequency (not significant because of small sample sizes) at several loci. Population C-64 at the northern edge of distribution shows more divergence, although only one locus, Tpi, reveals the presence of a fixed difference involving a unique allele. The most

divergent population is C-163, located at the southern end of the distribution. This population displays a number of fixed differences when compared with the other three populations (range 14-23%), although only three loci (Gpi, Pgm-1, and Tpi) involve alleles unique to C-163.

Clearly the null hypothesis of panmixia is refuted on the evidence of the allozyme data. The levels of genetic divergence are quite high, and by themselves might indicate the presence of more than one species. However, the data are not able to resolve this situation because of the allopatric nature of the distribution of the genetic types. The high levels of polymorphism, coupled with the fact that only a small component of the genetic distance estimates is due to the fixation of unique alleles, suggests that the concept of a single, highly variable species, consisting of discrete sub-populations is the more appropriate model.

The caves in Cape Range are formed in Tulki Limestone which is highly dissected by gorges, some of which cut into the Mandu Calcarene below. C-18 and C-103 are 4 km apart and are not separated by deep gorges cutting into the Mandu Calcarene. C-18 and C-64 are 5.5 km apart and are separated by deep gorges cutting into the Mandu Calcarene and exhibit 4% fixed differences. C-103 and C-163 are only 3.4 km apart but the latter is separated from the other caves by a major gorge which, however, does not appear to cut into the Mandu Calcarene as far as can be ascertained from surface geology maps. These major gorges are associated also with genetic discontinuities in terrestrial troglobites, but not in cave dwelling but non-troglobitic species (Humphreys 1990).

Continuity of the fauna

The possibility exists that the coastal aquatic fauna is continuous beneath Cape Range, where it cannot be sampled. The four caves in Cape Range which contain amphipods have all been surveyed. The water in the caves is at an altitude of from 110 m (C-64) to 240 m (C-103), whereas the freshwater lens beneath Cape Range has an expected elevation of <5 m (Hocking, Moors & van de Graaff 1987), perhaps as low as 0.7 m (calculated from the hydraulic gradient of 6 cm km⁻¹; Bestow 1966). No cave known from Cape Range approaches a depth where a continuation of the coastal fauna beneath Cape Range would have been sampled. If the coastal fauna extends beneath the range then the genetic distances between the populations would be expected to be correlated with the direct metric distance between the populations. If the populations are restricted to the coastal limestone then the genetic distances between the populations, would be expected to be correlated with their metric distance apart along the coastal plain, namely around the northern end of the peninsula. This analysis is appropriate as panmixia has already been rejected, hence this relationship will not be a straight line with a slope of zero (see Richardson, Baverstock & Adams 1986: 287). The two measures of genetic distance for the gudgeons were regressed on both these measures of metric distance (Appendix 4; this cannot be done for the shrimps because the samples for each species are restricted to either the east or the west coast).

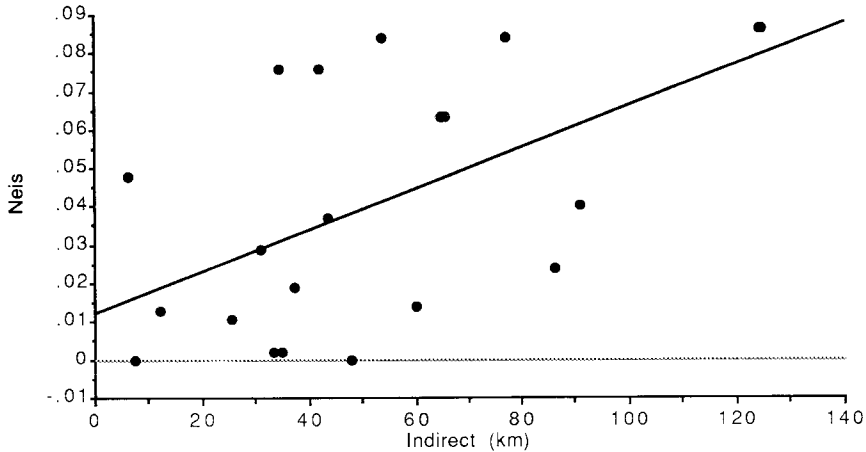

Figure 5. The relationship between Nei's Distance for the gudgeons and the indirect metric distance (km) which assumes the populations inhabit only the coastal plain.

No significant relationship was found between genetic separation of the gudgeon populations and the direct metric distance between the wells (Table 5). However, both measures of genetic distance were significantly regressed on indirect metric distance (assuming contact only along the coastal plain; Table 5, Figure 5). In addition there is a close relationship between metric and genetic distance for the shrimps, *S. lancifera* (Table 5, Figure 6). Together these analyses suggest that the coastal fauna on the North West Cape peninsula inhabits a linear system (corridor), and does not occupy the available water lens beneath Cape Range.

The form of these relationships does not fit that expected of the panmixia model (panmixia has already been rejected), nor the isolation by distance model in which the

Table 5. Summary of the statistics relating genetic distance between the gudgeon populations to two measures of metric distance between the sampling locations (see text), and the direct measure between shrimp (*S. lancifera*) populations.

Genetic Distance	Metric Distance	D.f.	Fs	P	r ² adj.	Intercept	Slope
Gudgeon							
Nei's	Direct	1,5*	1.062	>0.25	—	—	—
Nei's	Indirect	1,5	8.497	<0.05	0.273	0.012	0.00014
Fixed	Direct	1,5	0.313	>0.10	—	—	—
Fixed	Indirect	1,5	7.651	<0.05	0.250	-0.158	0.012
Shrimp							
Nei's	Direct	1,2	72.241	<0.03	0.934	-0.008	0.00036

*In Figs 5 and 6 each point represents a comparison between two of n populations and there are n(n-1)/2 points. As these are not statistically independent the degrees of freedom in the above analyses are based on n rather than n(n-1)/2 comparisons.

curve should be steep initially and gradually flatten out with increasing distance (see Richardson, Baverstock & Adams 1986: 287). This suggests that the discrete sub-population model may be appropriate but more detailed sampling would be required to verify this hypothesis as the sample sizes used here are too low for detailed analysis of population sub-structuring. Morton's Kinship Coefficient (not shown) is zero at a distance apart of 44 km; individuals at this distance can be considered independent of one another.

The consequences of non-panmictic cave populations have been discussed extensively elsewhere (Humphreys 1989). It is suffice to say that uncertainty about the extent of the interconnection of the fauna in the coastal system(s) complicates considerably potential management of the region. A more detailed analysis of the interconnections is required.

Groundwater

Nature of the water bodies

Water occurs in four of the caves in Cape Range for which the only evidence of continuity are the contained amphipods; one (C-64) is an outflow cave and always contains water, two caves contain accessible pools (C-18 and C-103; the former can silt up; Humphreys 1989), while the fourth (C-163) contains long water filled passages (R. Wood; pers. comm. 1988). The estimated height of the water in the caves is >100 m above the freshwater lens beneath Cape Range (see above). The latter is recharged after exceptional rain, and the coastal areas are recharged by run off from the range (Hocking, Moors & van de Graaff 1987). The coastal fauna probably occurs at the periphery of this freshwater lens barely above sea level (up to *ca.* 1.2 m; see above).

From the mouths of the gorges in Cape Range alluvial gravel deposits fan across the coastal plain (Sofoulis 1951a). In the foothills and on the coastal plain a wedge of freshwater overlies sea water so the water is more saline closer to the coast. Dissolved solids in the water increase from 430 mg L^{-1} near the scarp to more than 2850 mg L^{-1} near the coast. The successful bores are on these drainage lines, while between them water is absent or saline (Sofoulis 1951b). This could result in interfluvial salinity barriers to the dispersal of the coastal fauna, indeed all the known faunal sites are on these drainage lines.

The lateral hydraulic conductivity in the Exmouth bore field varies by three orders of magnitude (10 to 1000 m d^{-1} ; Forth 1973) and is indicative of the varied cavernous nature of the Mandu, Tulki and Trealla Limestones where the bores occur; cavernous flow can be seen at some coastal locations (*ibid.*). In such cavernous karst areas the sea water/freshwater interface is rarely found as a line of demarcation, as in a uniformly porous and permeable medium, but will occur as a broad irregular zone of diffusion which is broadest at the coast due to tidal influence and is reduced away from the sea (Forth 1973).

The influence of marine tides on the water level is not known in detail. There are daily tidal movements of 15 cm in Kudamurra, Tantabiddy and Milyering Wells on the west coast (Mees 1962). Bundera Sinkhole, a cenote, to the south of Yardie Creek clearly is

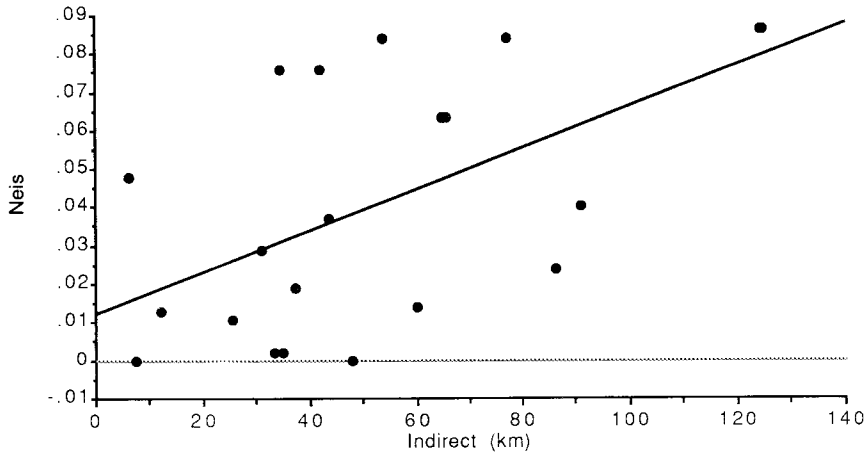

Figure 5. The relationship between Nei's Distance for the gudgeons and the indirect metric distance (km) which assumes the populations inhabit only the coastal plain.

No significant relationship was found between genetic separation of the gudgeon populations and the direct metric distance between the wells (Table 5). However, both measures of genetic distance were significantly regressed on indirect metric distance (assuming contact only along the coastal plain; Table 5, Figure 5). In addition there is a close relationship between metric and genetic distance for the shrimps, *S. lancifera* (Table 5, Figure 6). Together these analyses suggest that the coastal fauna on the North West Cape peninsula inhabits a linear system (corridor), and does not occupy the available water lens beneath Cape Range.

The form of these relationships does not fit that expected of the panmixia model (panmixia has already been rejected), nor the isolation by distance model in which the

Table 5. Summary of the statistics relating genetic distance between the gudgeon populations to two measures of metric distance between the sampling locations (see text), and the direct measure between shrimp (*S. lancifera*) populations.

Genetic Distance	Metric Distance	D.f.	Fs	P	r ² adj.	Intercept	Slope
Gudgeon							
Nei's	Direct	1,5*	1.062	>0.25	—	—	—
Nei's	Indirect	1,5	8.497	<0.05	0.273	0.012	0.00014
Fixed	Direct	1,5	0.313	>0.10	—	—	—
Fixed	Indirect	1,5	7.651	<0.05	0.250	-0.158	0.012
Shrimp							
Nei's	Direct	1,2	72.241	<0.03	0.934	-0.008	0.00036

*In Figs 5 and 6 each point represents a comparison between two of n populations and there are $n(n-1)/2$ points. As these are not statistically independent the degrees of freedom in the above analyses are based on n rather than $n(n-1)/2$ comparisons.

curve should be steep initially and gradually flatten out with increasing distance (see Richardson, Baverstock & Adams 1986: 287). This suggests that the discrete sub-population model may be appropriate but more detailed sampling would be required to verify this hypothesis as the sample sizes used here are too low for detailed analysis of population sub-structuring. Morton's Kinship Coefficient (not shown) is zero at a distance apart of 44 km; individuals at this distance can be considered independent of one another.

The consequences of non-panmictic cave populations have been discussed extensively elsewhere (Humphreys 1989). It is suffice to say that uncertainty about the extent of the interconnection of the fauna in the coastal system(s) complicates considerably potential management of the region. A more detailed analysis of the interconnections is required.

Groundwater

Nature of the water bodies

Water occurs in four of the caves in Cape Range for which the only evidence of continuity are the contained amphipods; one (C-64) is an outflow cave and always contains water, two caves contain accessible pools (C-18 and C-103; the former can silt up; Humphreys 1989), while the fourth (C-163) contains long water filled passages (R. Wood; pers. comm. 1988). The estimated height of the water in the caves is >100 m above the freshwater lens beneath Cape Range (see above). The latter is recharged after exceptional rain, and the coastal areas are recharged by run off from the range (Hocking, Moors & van de Graaff 1987). The coastal fauna probably occurs at the periphery of this freshwater lens barely above sea level (up to *ca.* 1.2 m; see above).

From the mouths of the gorges in Cape Range alluvial gravel deposits fan across the coastal plain (Sofoulis 1951a). In the foothills and on the coastal plain a wedge of freshwater overlies sea water so the water is more saline closer to the coast. Dissolved solids in the water increase from 430 mg L^{-1} near the scarp to more than 2850 mg L^{-1} near the coast. The successful bores are on these drainage lines, while between them water is absent or saline (Sofoulis 1951b). This could result in interfluvial salinity barriers to the dispersal of the coastal fauna, indeed all the known faunal sites are on these drainage lines.

The lateral hydraulic conductivity in the Exmouth bore field varies by three orders of magnitude (10 to 1000 m d^{-1} ; Forth 1973) and is indicative of the varied cavernous nature of the Mandu, Tulki and Trealla Limestones where the bores occur; cavernous flow can be seen at some coastal locations (*ibid.*). In such cavernous karst areas the sea water/freshwater interface is rarely found as a line of demarcation, as in a uniformly porous and permeable medium, but will occur as a broad irregular zone of diffusion which is broadest at the coast due to tidal influence and is reduced away from the sea (Forth 1973).

The influence of marine tides on the water level is not known in detail. There are daily tidal movements of 15 cm in Kudamurra, Tantabiddy and Milyering Wells on the west coast (Mees 1962). Bundera Sinkhole, a cenote, to the south of Yardie Creek clearly is

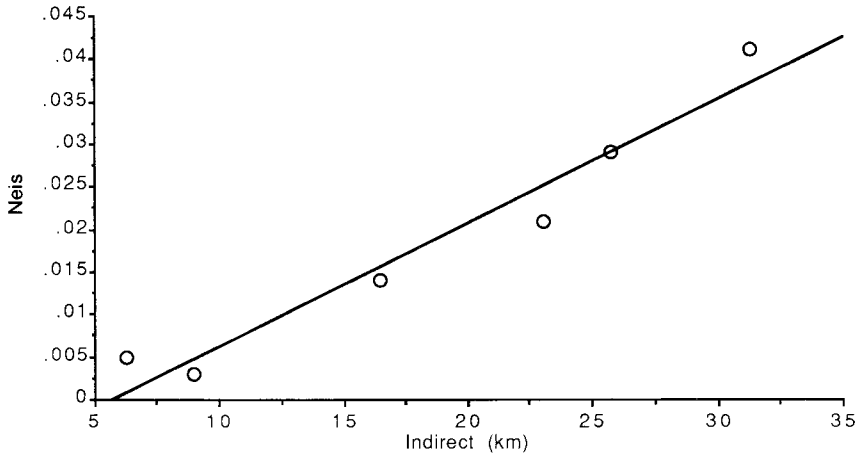

Figure 6. The relationship between Nei's Distance for the shrimp (*S. lancifera*) populations and the direct metric distance (km). No indirect measure of distance is available because all samples were from the west coast.

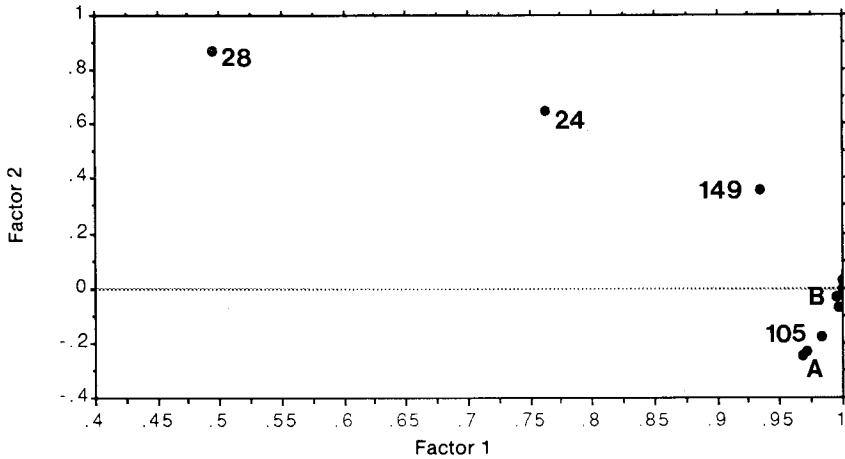

Figure 7. Unrotated orthogonal plot from a factor analysis on the parameters in Table 4 arranged by well number or name. Note that there is a trend in the data from the east coast, round the north coast and south down the west coast. Cluster A includes C-23, C-64, C-103 and C-163. Cluster B includes C-25, C-26, C-273, C-275 and Mangrove Bore.

also tidal. On the east coast, south of Exmouth, tidal effects on the groundwater level are evident up to *ca.* 3.5 km inland (Forth 1973) and this probably affects the draw capacity of the bores.

A model for population interaction

From the foregoing discussion it is evident that there is a band of decreasing salinity away from the coast. This is superimposed on fan-shaped channels of freshwater drainage broadening towards the coast and on the gradient in the thickness of the zone of mixing of fresh and saltwater. This information permits the development of a general model, with direction but not magnitude, of the likely form of the isohalines along the coast near the drainage lines from Cape Range. It can be seen (Figure 7) that any connections between populations along the coast, and hence gene flow, will likely be close to or in the foothills of Cape Range. These areas, away from productive wells and from known subterranean fauna, are likely to be the critical areas for conservation. While this model is contraindicated by the distributional data, it needs to be explored or else any management may be both misdirected and sidetracked. The gudgeons do indeed occur in at least one area of Tulki Limestone, well into the foothills of Cape Range (C-215; see above).

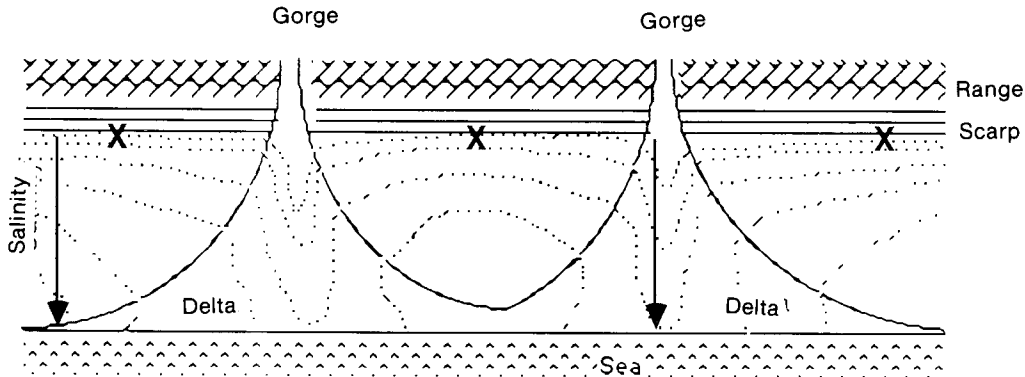

Figure 8. Schematic diagram of the scarp and coastal plain of the peninsula. The general form of the isohalines (.....) was determined from the evidence discussed in the text. The wells, hence the coastal fauna, are known mainly from the fan shaped drainage areas below the mouths of gorges in Cape Range. X marks the narrow corridor of lower salinity hypothesised to be close to or in the foothills of Cape Range and through which the populations may connect.

Water quality

The fauna inhabits water from which samples vary in salinity from 0 (C-23) to 16‰ (Bundera Sinkhole; Tables 2 and 6). Excluding the latter the salinity range is from 0 to 5‰ and a more detailed analysis of Bundera Sinkhole should be made to confirm this anomalous reading. Such coastal freshwater usually floats on a saltwater wedge but no salinity profiles have been conducted in these wells. The pH range of 6.8-7.6 (mean 7.3 [S.D. 0.29, N=11]) is characteristic of limestone areas with fast flowing water (Culver 1982).

The results of water chemistry analysis from some of the wells on the coastal plain and from caves in Cape Range are presented in Table 6. A factor analysis by sample location shows that there is a cline in the quality of the water, with a gradual increase in ionic content anti-clockwise around the coast, from the caves in Cape Range, down onto the east coastal plain, around the north coast and on down the west coast to the south of Yardie Creek (Figure 8). Linear regression analysis (Table 7) shows that most of the parameters exhibit a significant cline in this direction. If the anomalous data from Bundera Sinkhole (C-28) are excluded, salinity (log) is still significantly regressed on distance (log) ($F_{s,1,10} = 5.367$, $P=0.043$; $r^2_{adj.} = 0.284$).

Groundwater salinities in the Carnarvon Basin, of which the peninsula is a part, show a systematic increase in the direction of the groundwater flow (Hocking, Moors & van de Graaff 1987: 239), with the exception of areas of very saline groundwater such as occur on the coastal plain to the east of Exmouth Gulf (*ibid.*). This appears to be the case around Cape Range. Groundwater flow should radiate from the range but the only long reach is south of the range; it is in this downstream area that the ionic content of the groundwater is greatest. Elsewhere on the peninsula the sampling resolution is too low to detect this.

Examination of the known range of the parameters reveals that the coastal fauna inhabits a wide range of water chemistries (Table 8). The amphipods from the caves in Cape Range inhabit a narrower range of these parameters but, as a wider range of parameters does not occur within Cape Range, the data are not informative as to the tolerance of the amphipod species involved. The most notable feature is the high level of total nitrogen in the caves in Cape Range compared with the water bodies on the coastal plain.

Table 6. The results of water analysis from caves within Cape Range and from wells and bores on the coastal plain. The locations are shown in Figure 1.

Cave Number	Cave name	Salinity ‰	Na ⁺ mM/L	K ⁺ mM/L	Ca ⁺⁺ mM/L	Mg ⁺ mM/L	Cl ⁻ mM/L	Total P µg/L	Total N µg/L
C-23	Dozer Cave	0.0	3.60	0.04	0.21	0.19	2.04	9	193
C-24	Milyering Well	4.0	55.80	1.12	2.90	4.80	58.70	9	68
C-25	Kudamurra Well	2.0	21.20	0.45	1.67	2.87	23.20	4	114
C-26	Tantabiddy Well	5.0	41.10	0.81	2.47	4.54	39.60	32	207
C-28	Bundera Sinkhole	16.0	248.70	5.44	5.72	23.40	253.70	21	167
C-64	Shot Hole Tunnel*	0.0	1.59	0.03	0.74	0.46	2.10	4	187
C-103	Trionomo*	0.0	0.88	0.01	1.18	0.09	1.48	14	286
C-105	The Gnamma Hole	1.0	7.34	0.15	0.75	1.10	7.73	3	134
C-149	Tulki Well	3.0	66.70	1.36	3.31	7.00	70.50	7	141
C-163	Wanderer's Delight*	0.5	1.59	0.02	1.33	0.19	2.35	4	174
C-273	5 Mile Well	4.0	57.80	1.18	3.03	5.94	59.50	23	259
—	Mangrove Bore	1.5	13.90	0.31	1.53	2.30	15.54	3	101

*Denotes caves in Cape Range rather than wells on the coastal plain; the two areas have no fauna at the level of Order in common.

Together, Tables 4 and 8 suggest that within the known range of the coastal subterranean fauna all sampled sites have a water chemistry suitable for habitation. Hence, the absence of fauna from any water body within this range is likely to be explained by the isolation of that water body from adjacent inhabited water. Such absence may result from lack of continuity of adequately sized cavities within the coastal limestone, or from a temporary drop in the water table which would prevent recolonisation following local extinction due to the stochastic processes operating on small populations.

Table 7. Results of regression analysis of various water chemistry parameters ($\log [Y+1]$) on distance around the coast ($\log [X+1]$) of the North West Cape peninsula. The distance is measured from the most southerly cave on the east coast, around the north coast and down the west coast, hence it is assumed that the water body is coastal and does not continue beneath Cape Range. It illustrates the significant cline in most water chemistry parameters.

Parameter	Fs	P
Salinity (‰)	7.80	0.018
Na ⁺ (mM/L)	10.30	0.008
K ⁺ (mM/L)	9.94	0.009
Ca ⁺⁺ (mM/L)	13.72	0.004
Mg ⁺ (mM/L)	12.91	0.004
Cl ⁻ (mM/L)	10.61	0.008
Total P (µg/L)	2.44	0.147
Total N (µg/L)	2.26	0.161

Status of the water table

The Water Authority of Western Australia consider that the water being drawn from the Exmouth bore field is connate water, namely recharge not 'fossil water (pers. comm. 1989), and that there is plenty of space left to expand the bore fields (pers. comm. 1988). While this water is heavily drawn upon there appears to have been no consistent monitoring of the level, depth of the saline layer or the quality of the water in the areas known to be inhabited by the subterranean fauna; monitoring bores have recently been added to the Exmouth bore field. There is consistent evidence, of diverse types and sources, that the water table and water quality are falling, but it is not known whether this has resulted from fluctuations in the rainfall or from the extraction of the water for human use. That the latter is the cause, at least within the Exmouth bore field, is indicated by the rising salinity of this water supply (Water Authority of Western Australia; pers. comm. 3 February 1988).

The North West Cape peninsula of Western Australia lies just within the tropics. This semi-arid region is in that part of Australia with the least predictable rainfall, with both the constancy and contingency (*sensu* Colwell 1974) being low (Humphreys, Adams & Vine 1989). In consequence there is low probability of rainfalls sufficient to flood deeply the caves within the range (see full discussion in Humphreys, Adams & Vine 1989), and the recharge pattern of the coastal groundwater will be similarly influenced.

Table 8. The known range of various of water chemistry parameters within which the various taxa of subterranean species have been found.

Parameter	Shrimps ¹	Eel ¹	Gudgeon ¹	Amphipods ²
pH 1988	6.8-7.5	6.8-7.3	6.8-7.5	6.8
Salinity (‰)	2-5	1-5	0-161	0-0.5
Na ⁺ (mM/L)	21.2-66.7	7.34-55.80	3.60-248.70	0.88-1.59
K ⁺ (mM/L)	0.45-1.36	0.45-1.12	0.04-5.44	0.01-0.03
Ca ⁺⁺ (mM/L)	1.67-3.31	0.75-2.90	0.21-5.72	0.74-1.33
Mg ⁺ (mM/L)	2.87-7.00	1.10-4.80	0.19-23.4	0.09-0.46
Cl ⁻ (mM/L)	23.2-70.5	7.73-58.70	2.04-253.7	1.48-2.35
Total P (µg/L)	4-9	3-32	4-21	4-14
Total N (µg/L)	68-141	68-207	68-193	174-286

¹These species occur exclusively as subterranean fauna of the coastal plain; the Blind Cave Eel, (*O. candidum*), being too rare, is the only member of the fauna not represented in the analysis. ²Amphipods occur exclusively in caves in Cape Range, where they are the only aquatic fauna.

The evidence

Several bores have dried up or gone saline in the Joint Naval Communications Facility, to the north of the Exmouth bore field (L. Banfield; pers. comm. and *Exmouth Expression*, February 1989: 6). Town Well has become more saline and a number of other wells have dried up (Cape Well, Trealla Well and South Yardie Well), or the water level has been substantially lowered (Neds Well, C-119, Milyering Cave, Tantabiddy Well; B. Vine, pers. comm. 1989). The presence of recent bores alongside many of the wells is an indication of lowering water table. In addition a number of natural seepages from the scarp slopes have dried up e.g. Maduradura gorge (flow greatly diminished; 'used to be able to swim but can now hardly get wet feet'), a spring in Shot Hole Canyon (dried up mid to late 1970's; 'used to flow continuously but is now not even damp') and Padjari Manu (formerly Bunbury cave) in which there used to be a permanent soak into a gour pool but since the mid 1970's has been dry except after heavy rain (B. Vine, pers. comm. 1989); this was a traditional site for aboriginal people (Site Reference P0267).

The trend in water use in Exmouth was described as 'alarming' (Water Authority of Western Australia; pers. comm. 3 February 1988), even before the major development of the area was mooted. The salinity of the water extracted from the Exmouth bore field is constantly rising (*ibid.*) but it is not known whether this results from saltwater coning below the bore or from a general rise in the level of the saltwater. Clearly this is not a sustainable usage and if it continues lasting damage may be done to both the water supply and the habitat of the subterranean fauna. Extension of the bore field, the current method of management (*ibid.*), will extend the area over which this damage occurs. Considerable accuracy (± 5 mm) is required to monitor changes in water level and salinity because changes need to be distinguished from the tidal influence reported in these bores and because a mere 75 mm lowering of the water table would reduce freshwater storage by 20% (Forth 1973)

Age

The age of isolation of troglobitic species remains controversial. Some authors claim a general trend/pattern for cave fauna. In general aquatic cave species are considered to have been isolated in caves for longer periods than terrestrial species, up to 2000 k yr BP (Hobbs and Barr 1972) or even earlier (Holsinger 1978). Of the species examined from North West Cape peninsula the aquatic amphipods show the most genetic divergence between caves (Humphreys 1990), while within the coastal fauna speciation has occurred in the shrimps. However, some other aquatic groups are considered to have been isolated more recently; <10 k yr BP in the Mexican characin *Astyanax mexicanus* (Mitchell, Russell & Elliott 1977) and between 20 and 0.09 k yr BP for the diverse Hawaiian larva tube fauna, but the latter may be complicated by the ability of the species to move between caves (Howarth 1972). Peck (1981a, 1981b) has suggested pulses in the rate of isolation of putative troglobites in caves of the Grand Canyon during Pleistocene interglacials, namely >350, 320-275, 235-185, 150-90 and <15 k yr BP.

The coastal plain limestones on the North West Cape peninsula originate from fringing coral reefs during periods of higher sea level. There are three higher terraces along the west coast scarp of Cape Range, to a height of *ca.* 57 m above the present sea level, which are thought to represent stadia in the Quaternary sea levels changes (Graaff, Denman & Hocking 1976). The high degree of troglobitic adaptation in the species suggests that the coastal subterranean fauna is of an age such that it did not evolve *in situ* in the current limestones (Mees 1962). They could not have occupied the current coastal limestone during the high sea levels, at which time Cape Range (together with Rough Range) would have been an island, separated from Giralia Range, and large areas of the hinterland of Cape Range would have been inundated by the sea.

With the changing sea levels following the uplift of the Miocene limestones into the Cape Range anticline, there has been ample opportunity for the present coastal fauna to have colonised water within Cape Range itself or to have evolved there and subsequently moved down to their present location. However, the lack of common fauna (no common Orders) between Cape Range and the coastal plain (Humphreys 1989), despite the suitability of the water and probable opportunity for its invasion (superficial speleothem material from C-163 has been dated by Th/Ur method at 123014 y BP [+50886, -34814]; D. Smith, pers. comm. 1990) suggests neither to be the case.

Alternatively the coastal fauna may have arrived in the area by migration along the coast in similar limestones with connecting water channels. Current conditions (not considering sea level changes) preclude migration along the coast owing to the highly saline groundwater to the east (along the shore of Exmouth Gulf) and to the south (salinity is high [Hocking, Moors & van de Graaff 1987] and traditional water sources were lacking [Carter 1902]). Indeed, there is currently a barrier of high salinity (>6000 mg L⁻¹ total dissolved solids) in the unconfined groundwater across the neck of the peninsula (Hocking, Moors & van de Graaff 1987: 240).

Milyeringa's closest affinity is possibly with the eleotridid genus *Butis*. *Butis* is a mangrove dwelling genus of brackish and fresh waters of the Indo-Australian

Archipelago (i.e. Malay Peninsula to northern Australia including Indonesia, Philippines and most of Melanesia) (G.R. Allen; pers. comm. 1990). At the height of the Pleistocene glaciation, when sea level was 150 m lower than the present level (Chappell & Thom 1977), the western shore would have been no more than 12 km from the current shoreline (Morse 1988). Such slow lateral migration of the shoreline, over what are presumably coastal limestone deposits, offer an alternative route for immigration onto the North West Cape peninsula along a broad coastal plain.

Hence, it may be worth searching wider afield for this fauna or for related faunae. However, the cline in salinity, increasing to the south-west, suggests that isolation may have resulted from increasing salinity in the groundwater as the climate dried. Adjacent to Cape Range the groundwater is recharged from water captured in the limestone of the range. The water supply here is probably more consistent and less saline than in adjacent coastal areas without an elevated hinterland, thus permitting the fauna to survive.

Concluding remarks

The karst area on North West Cape contains a very rich troglobitic fauna (Humphreys 1989, 1990; Humphreys, Adams & Vine 1989). Some of the caves and wells lie within Cape Range National Park where legislation provides for the 'protection of indigenous . . . fauna and . . . any feature of scientific interest' and management objectives aim to 'protect and conserve indigenous . . . animals and their habitats', to 'maintain scientific reference areas' and to 'conserve and protect groundwater resources' (CALM 1987). However, informed management of the coastal subterranean aquatic fauna is hampered by its main distribution being outside Cape Range National Park and by the lack of information on the biology of the fauna and the characteristics of the subterranean water. Recent sightings of the eel lie in the area of greatest development and the other species occur as isolated populations on the north-west and east coasts are outside the area of protection, as are two of the four amphipod localities, all lying in a temporary limestone reserve (TR5980H), under the authority of the Minister for Mines.

The fauna is presumably dependent upon allochthonous energy sources washed into the system during heavy rain (Humphreys, Adams & Vine 1989), although in C-215 it may receive substantial energy inputs from the dense root mats, and their exudates (Culver 1982) which penetrate the cave system; the extent of these is unknown as the coastal subterranean caverns are rarely accessible to people, but a characteristic fauna associated with such root mats seems absent. The total nitrogen levels in the coastal waters is much lower than found in Cape Range.

Alteration to the quantity or quality of the water in the caves and wells of the North West Cape peninsula will affect the populations of aquatic troglobites, as changes affecting the Tulki Limestone will influence the humid adapted terrestrial troglobites of Cape Range (Humphreys 1989; Humphreys, Adams & Vine 1989; Humphreys & Collis 1990).

At this stage little is known of the water bodies within Cape Range other than, as there is no common fauna, they are isolated from those of the coastal plains. The genetical

evidence from the amphipods within Cape Range suggests that the major gorges separate not only the populations, but also the water bodies they inhabit (Humphreys, Adams & Vine 1989). In addition the genetical evidence from the coastal plain suggests that there may be partially separate water bodies also along the coastal plain. A faunal survey would have the advantage of determining the extent of the Cape Range fauna and the continuity of the water bodies.

Cave faunae generally, even terrestrial components, are vulnerable to change in the water table. *Schizomus wessoni* (Chamberlin) was eliminated from its type locality due to long term drying of the Santa Cruz River due to agricultural activities, and oases were rendered unsuitable for *S. joshuensis* by draining (Rowland & Reddell 1981). *Schizomus vinei* inhabits many caves within Cape Range, and with its associated fauna is highly dependent on the status of hydration of the caves, being derived from a tropical wet forest community (Humphreys 1989; Humphreys, Adams & Vine 1989).

Dewatering during the construction of the proposed Exmouth marina could be expected to affect the area within a 1000 m radius (Morgan and Associates 1990: 16). This will cause the saltwater wedge to move further inland and potentially bisect the known distribution of all species of the subterranean aquatic fauna. While this paper shows that knowledge of the distribution of this coastal fauna is sparse and fragmentary, the information available has led to a testable model. This suggests that the critical areas for conservation are not, as would seem obvious, those areas from which the fauna has been recorded, but the likely narrow corridors of freshwater close to the scarp between the areas from which the fauna has been recorded. Any future management strategy should consider this model.

Acknowledgements

We are grateful to a number of former and present residents of Exmouth for their experience with the local caves and wells over many years, especially Len Banfield, Malcolm East and Brian Vine. For assistance in obtaining samples we thank John Bass, Darren Brooks, Malcolm East, Brian Vine and Ray Wood. Diana Jones offered me advice on the shrimps and Caroline Lawrence drew the map. Jan Birrell provided expert technical assistance. Dr B. Knott kindly provided much of the data on water chemistry. Dr D. Smith, University of Melbourne, conducted the Th/Ur analysis. The Department of Conservation and Land Management permitted work within Cape Range National Park and the Lessees permitted work on Exmouth Gulf Station. The coastal samples were collected incidentally to work in Cape Range for which the field work was funded by the Australian National Parks and Wildlife Service, The National Heritage Committee and by the Western Australian Museum. The electrophoretic work was funded by the Australian National Parks and Wildlife Service.

I thank the referees for their advice on distribution records and statistics.

Appendices

Appendix 1: Genetic data for the Blind Gudgeon, *Milyeringa veritas*.

Appendix 1a: Allele frequencies for the seven populations of gudgeon. Alleles are designated alphabetically with 'a' being the most cathodal. Where present, multiple loci are designated numerically according to increasing electrophoretic mobility.

LOCUS	allele	Well						
		C-25 Kudamurra	C-149 Tulki	C-273 5 Mile	C-274 Pilgramunna	C-362 Javis	C-361 Mowbowra	C-27 Kubura
<u>Enol-2</u>	b			75			100	100
	a	100	100	25	100	100		
<u>Fum</u>	b	90	100	100	100	100	100	100
	a	10						
<u>Acon-2</u>	c					25		
	b	90	90	100	100	75	100	100
	a	10	10					
<u>PepB</u>	b	90	100	100	100	100	100	100
	a	10						
<u>Ldh-1</u>	b	50	80	67			100	100
	a	50	20	33	100	100		
<u>Idh-1</u>	b	90	100	100	100	100	100	100
	a	10						
<u>Idh-2</u>	c	20	60	93	75	100	100	100
	b	80	40		25			
	a			7				
<u>Pgm-2</u>	b				12			
	a	100	100	100	88	100	100	100
<u>Mdh-3</u>	b		40	100	37	25	100	100
	a	100	60		63	75		
<u>Ca</u>	b	100	100	100	87	100	100	100
	a				13			
<u>Gpi-1</u>	b	50	100	42	100	100		
	a	50		58			100	100
<u>Sordh</u>	b	80	62	100	87	75	100	100
	a	20	38		13	25		
Maximum N		5	5	7	5	2	3	3

Invariant loci: Acon-1, Ada, Adh, Ak, Ald-1, Ald-2, Ck, Enol, Est, Fdp-1, Fdp-2, Gapd, Glo, Got-1, Got-2, Gp-1, Gp-2, Gpi-2, Gpt, Ldh-2, Mdh-1, Mdh-2, Me, Mpi, PepD, Pgam, 6Pgd, Pgk, Pgm-1, Pk and Tpi.

Appendix 1b: Genetic distance matrix. Upper = Nei's Distance (corrected for small sample size, Nei 1978); lower = Fixed Differences (%).

Well	C-25	C-149	C-273	C-274	C-362	C-361	C-27
C-25	—	0.011	0.048	0.019	0.024	0.076	0.076
C-149	0	—	0.029	0.013	0.014	0.063	0.063
C-273	2	0	—	0.037	0.040	0.002	0.002
C-274	0	0	0	—	0.000	0.084	0.084
C-362	0	0	0	0	—	0.086	0.086
C-361	5	5	0	7	7	—	0.000
C-27	5	5	0	7	7	0	—

Appendix 2: Genetical data for the atydid shrimps *Stygiocaris* spp.

Appendix 2a: Allele frequencies for the six shrimp populations. Data from C-361 and C-27 are for *S. stylifera* while the remaining four localities are from *Stygiocaris lancifera*.

LOCUS	allele	Well					
		C-273 5 Mile	C-24 Milyering	C-25 Kudamurra	C-149 Tulki	C361 Mowbowra	C-27 Kubura
<u>Acon</u>	d				25		
	c	100	100	100	75		
	b					83	100
	a					17	
<u>Acyc-2</u>	b	25					
	a	75	100	100	100	100	100
<u>Argk-1</u>	b						6
	a	100	100	100	100	100	94
<u>Argk-2</u>	b				12	100	100
	a	100	100	100	88		
<u>Est-1</u>	b	100	100	100	100		
	a					100	100
<u>Est-2</u>	c	100	100	100	100		
	b					100	87
	a						13
<u>Gapd</u>	b					100	100
	a	100	100	100	100		
<u>Got-1</u>	d			12			
	c					17	
	b	75	12	75		83	100
	a	25	88	13	100		
<u>Got-2</u>	c					100	100
	b	37	87	87	100		
	a	63	13	13			

Appendix 2a cont.

<u>Gpi</u>	c	12				50	31
	b						6
	a	88	100	100	10	50	83
<u>Gpt</u>	c	37	25	37			
	b	63	75	63	100		
	a					100	100
<u>Hk</u>	b	100	100	100	100		
	a					100	100
<u>Mpi</u>	b					100	100
	a	100	100	100	100		
<u>PepA</u>	b	100	100	100	100		
	a					100	100
<u>PepB-1</u>	b	100	100	100	100		
	a					100	100
<u>PepB-2</u>	b	100	100	100	100		
	a					100	100
<u>PepD-1</u>	b	100	100	100	100	50	100
	a					50	
<u>Sordh</u>	b	100	100	100	100		
	a					100	100
<u>Tpl</u>	b	100	100	100	100		
	a					100	100
Maximum N		4	4	4	4	3	8

Invariant loci: Acyc-1, Ald, Enol, Fdp, Fum, Gda, Gp, Ldh and PepD-2.

Appendix 2b: Genetic distance matrix. Upper = Nei's Distance (corrected); lower = Fixed Differences (%).

Well	C-273	C-24	C-25	C-149	C-361	C-27
C-273	—	0.021	0.005	0.041	0.742	0.708
C-24	0	—	0.014	0.003	0.787	0.758
C-25	0	0	—	0.029	0.739	0.704
C-149	0	0	0	—	0.791	0.783
C-361	50	50	50	50	—	0.006
C-27	50	50	50	50	0	—

Appendix 3: Genetical data for the Amphipoda from four caves in Cape Range.**Appendix 3a:** Allele frequencies of Amphipoda.

LOCUS	allele	C-18	C-64	C-103	C-163
<u>Acon-1</u>	b				17
	a	100	100	100	83
<u>Acyc</u>	b	100	50		100
	a		50	—	
<u>Adh</u>	b	12	100		
	a	88		—	100
<u>Fdpase</u>	b	50		100	100
	a	50	100		
<u>Gapd</u>	b		28		100
	a	100	72	100	
<u>Got-1</u>	b	62	78		100
	a	38	22	100	
<u>Got-2</u>	b				6
	a	100	100	100	94
<u>Gpi</u>	e				5
	d				89
	c				6
	b	75	100	100	
	a	25			
<u>Idh</u>	b	100	100	100	39
	a				61
<u>Lap</u>	b	100	50		100
	a		50	—	
<u>Mpi</u>	b	12			
	a	88	100	100	100
<u>PepB-1</u>	b		17		
	a	100	83	—	100
<u>PepB-2</u>	a	100	100	—	100
<u>PepD</u>	c				56
	b	75	100	37	44
	a	25		63	
<u>6Pgd</u>	a	100	100	—	100
<u>Pgm-1</u>	c				100
	b	100	83	100	
	a		17		

Appendix 3a cont.

<u>Tpi</u>	c	100	100	100	100
	b				
	a				
Maximum N		4	9	4	9

Invariant loci: Acon2, Enol, Gp-1, Gp-2, Gpt, Ldh, Mdh-1, Mdh-2, PepA, Pgm-2 and Pk.

Appendix 3b: Genetic distance matrix. Upper = Nei's Distance (corrected); lower = Fixed Differences (%).

Cave	C-18	C-64	C-103	C-163
C-18	—	0.108	0.033	0.194
C-64	4	—	0.155	0.286
C-103	0	9	—	0.310
C-163	14	18	23	—

Appendix 4: Distances between caves and wells.

Appendix 4a: Matrix of the distance between the wells on the North West Cape peninsula. Upper right: shortest distance (km) between all pairs of wells. Lower left: distance (km) around the north of the peninsula under the assumption that the subterranean aquatic fauna does not live beneath Cape Range.

	C-24	C-25	C-27	C-149	C-273	C-274	C-361	C-362
C-24	—	17	22	9	23	21	20	69
C-25	17	—	13	26	6	38	16	86
C-27	50	35	—	29	10	40	8	87
C-149	9	26	65	—	31	12	25	60
C-273	23	6	34	31	—	44	17	91
C-274	69	38	54	1	44	—	35	48
C-361	58	42	8	66	35	77	—	80
C-362	69	86	124	60	91	48	125	—

Appendix 4b: Matrix of the distance (km) between all pairs of caves in Cape Range containing amphipods.

	C-18	C-64	C-103	C-163
C-18	—	5.8	3.8	7.5
C-64		—	9.0	11.5
C-103			—	3.3
C-163				—

References

- Allen, G.R. 1982. *Inland Fishes of Western Australia*. Western Australian Museum, Perth.
- American Public Health Association. 1965. *Standard Methods for the Examination of Water and Wastewater*. (12th edition). American Public Health Association, Inc., New York.
- Bestow, T. T. 1966. Reappraisal of groundwater prospects at Exmouth Township for the Department of Public Works. Hydrology Report No. 300. Geological Survey, Western Australia.
- CALM. 1987. *Parks and reserves of the Cape Range Peninsula. Part 1: Cape Range National Park draft management plan: 1987-1997*. Department of Conservation and Land Management, Perth.
- Carter, T. 1902. Exploration of the North-West Cape. *The Emu* 2: 77-84.
- Cawthorn, P. 1953. Discovery of subterranean freshwater fauna on the eastern side of North West Cape. *Western Australian Naturalist* 8: 129-132.
- Chappell, J. & Thom, B.G. 1977. Sea levels and coasts. pp. 275-292. In Berger, R. and Suess, H. (Eds). *Sunda and Sahul: prehistoric studies in Southeast Asia, Melanesia and Australia*. Academic Press, London.
- Colwell, R. K. 1974. Predictability, constancy, and contingency of periodic phenomena. *Ecology* 55: 1148-1153.
- Condon, M. A., Johnstone, D. and Perry, W. J. 1955. The Cape Range Structure, Western Australia. Part I. Stratigraphy and Structure; Crespin, I. ; Part II. Micropalaentology. *Bureau Mineral Resources, Geology and Geophysics. Australia. Bull. No. 21*.
- Culver, D.C. 1982. *Cave life: evolution and ecology*. Harvard University Press.
- Forth, J. R. 1973. Exmouth water supply. pp. 11-15. *Geol. Surv. West. Aust., Ann. Rep. 1972*.
- Graaff, W. J. E. van de, Denman, P.D. & Hocking, R.M. 1976. Emerged Pleistocene terraces on Cape Range, Western Australia. *W. Aust. Geol. Survey Ann. Rep. 1975*: 62-70. Hamilton-Smith, E. 1967. The arthropoda of Australian caves. *J. Aust. ent. Soc.* 6: 103-118.
- Hobbs, H. H. II. & Barr, T.C. 1972. Origins and affinities of the troglobitic crayfishes of North America (Decapoda: Astacidae). II. Genus *Orconectes*. *Smithsonian Contributions to Zoology No. 105*.
- Hocking, R.M, Moors, H.T. & van de Graaff, W.J.E. 1987. Geology of the Carnarvon Basin, Western Australia. *Geol. Surv. West. Aust. Bull.* 133: 1-289.
- Holsinger, J.R. 1978. Systematics of the subterranean amphipod genus *Stygobromus* (Crangonyctidae). II. Species of the eastern United States. *Smithsonian Contributions to Zoology No. 266*.
- Holthuis L.B. 1960. Two new species of Atydid shrimps from subterranean waters of N.W. Australia (Decapoda Natantia). *Crustaceana* 1: 47-57.
- Howarth, F.G. 1972. Cavernicoles in larva tubes on the island of Hawaii. *Science, New York* 175: 325-326.
- Humphreys, W.F. 1989. The status of relict cave fauna of Cape Range, Western Australia, especially the Schizomida. *Report to the Australian National Parks and Wildlife Service, Canberra*. 104 pp.
- Humphreys, W.F. 1990. The biology of a troglobitic schizomid (Chelicerata: Arachnida) from caves in the semi-arid Cape Range, Western Australia. *Acta zool. Fenn.* 190:181-186.
- Humphreys, W.F., Adams, M. & Vine, B. 1989. The biology of *Schizomus vinei* (Chelicerata: Schizomida) in the caves of Cape Range, Western Australia. *J. Zool., Lond.* 217: 177-201.
- Humphreys, W.F. & Collis, G. 1990. Water loss and respiration of cave arthropods from Cape Range, Western Australia. *Comp. Biochem. Physiol.* 95A: 101-107.
- Mees, G.F. 1962. The subterranean fauna of Yardie Creek station, North West Cape, Western Australia. *J. Roy. Soc. West. Aust.* 45: 24-32.
- Michaelis, F. 1985. *Threatened fish. A report on the threatened fish of inland waters of Australia. Report Series No. 3*. 45 pp. Australian National Parks and Wildlife Service Canberra.
- Mitchell, R.W., Russell, W.H. & Elliott, W.R. 1977. Mexican eyeless characin fishes, genus *Astyanax*: environment, distribution, and evolution. *Special Publications. The Museum, Texas tech University. No. 12*.
- Morgan, K.H. & Associates 1990. *Project No. 691.02. Report on the trial excavation at the proposed small boat harbour, Exmouth, Western Australia for the Department of Marine and Harbours*. 4 January 1990.

- Morse, K. 1988. Mandu Mandu Creek rockshelter: Pleistocene human coastal occupation of North West Cape, Western Australia. *Archaeol. Oceania* **23**: 31-88.
- Nei, M. 1978. Estimation of average heterozygosity and genetic distance from a small number of individuals. *Genetics* **84**: 585-590.
- Peck, S.B. 1981a. The geological, geographical, and environmental setting of cave faunal evolution. *Proceedings of the Eighth International Congress of Speleology, Bowling Green, Kentucky*. **2**: 501-502.
- Peck, S.B. 1981b. Evolution of cave Cholevinae in North America (Coleoptera: Leiodidae). *Proceedings of the Eighth International Congress of Speleology, Bowling Green, Kentucky*. **2**: 503-505.
- Richardson, B.J., Baverstock, P.R. & Adams, M. 1986. *Allozyme electrophoresis: a handbook for animal systematics and population studies*. Academic Press, Sydney.
- Rowland, J.M. & Reddell, J.R. 1981. The order Schizomida (Arachnida) in the New World. IV. *goodnightorum* and *briggsi* groups and unplaced species (Schizomidae: *Schizomus*). *J. Arachnol.* **9**: 19-46.
- Sofoulis, J. 1951a. Report on gravel deposits, Learmonth. p. 69. *Geol. Surv. West. Aust., Ann. Rep. 1949*.
- Sofoulis, J. 1951b. Notes on water supply, Exmouth Gulf area. pp. 70-71. *Geol. Surv. West. Aust., Ann. Rep. 1949*.
- Vine, B., Knott, B. & Humphreys, W.F. 1988. Observations on the environment and biology of the *Schizomus vinei* (Chelicerata: Schizomida) from Cape Range, Western Australia. *Rec. West. Aust. Mus.* **14**: 21-34.
- Whitley, G. P. 1945. New sharks and fishes from Western Australia. Part 2. *Aust. Zool.* **11**: 35-37.
- Whitley, G. P. 1960. *Native freshwater fishes of Australia*. Jacaranda Press, Brisbane.